

(a) Schematic diagram

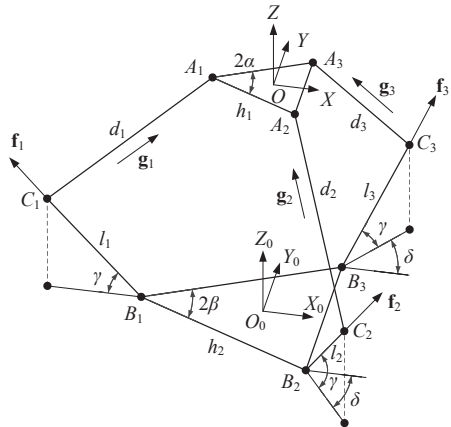

(b) Kinematic description

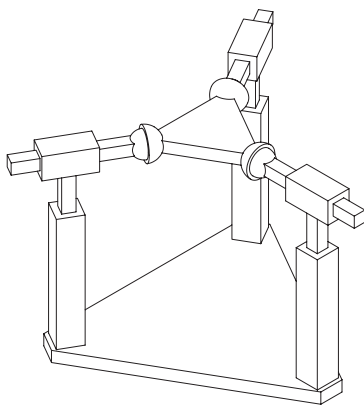

(c) A special case with  $\gamma = 90^\circ$